

Spreckels Memorial District  
**REGULAR MEETING OF THE BOARD OF DIRECTORS**  
**Wednesday October 6, 2021 5:30 pm**  
 Spreckels Veterans Memorial Building, 5<sup>th</sup> & Llano, Spreckels, CA 93962

### AGENDA

*Agenda order may be adjusted by Chair for purposes of meeting flow and to be respectful of the time concerns of guests present.*

1. CALL TO ORDER:

2. PLEDGE OF ALLEGIANCE:

3. ROLL CALL & ESTABLISHMENT OF QUORUM:

Rick Magno, President  
 Walan Chang, Vice-President  
 David Kuhlmann, Director  
 Jill Kramm, Director  
 Saren Pierson, Secretary

4. PUBLIC COMMENTS: *At this time any person may comment on any item which is not on the agenda. Please state your name and address for the record. Action will not be taken on any item that is not on the agenda. If it requires action, it will be referred to staff and/or placed on the next agenda. Board members may briefly respond to statements made or questions posed as permitted by Government Code Section 54954.2. In order that all interested parties have an opportunity to speak, please limit comments to a maximum of five (5) minutes. Any member of the public may comment on any matter listed on this agenda at the time the matter is being considered by the Board of Directors.*

5. APPROVAL OF MINUTES:

- a. SMD Regular Board Meeting September 8, 2021
- b. SMD Special Board Meeting September 21, 2021

6. BUSINESS MANAGER'S REPORT:

- a. Financial Reports February.
  - 1. Fund Balances as of 10/06/2021
  - 2. Budget FY 2021 FYTD to 9/30/2021

Spreckels Memorial District • P.O. Box 7266 • Spreckels, CA 93962  
 Park & Memorial Building Rental (831) 455-2022 • District Business (831) 455-7855  
 Email: spreckelsmd.main@gmail.com • www.spreckelsmd.specialdistrict.org

3. Review of Deposits: County Fund 668 June [Periods 13 & 14]
4. Review of Deposits: Wells Fargo General Checking September.
5. Review of Wells Fargo Bank Statements/Reconciliations August 2021.
6. Review of Expenditures August 2021

7. ACTION ITEMS: DISCUSSION AND POSSIBLE APPROVAL

- a. Approve Transfer of \$60,000.00 from County Fund 668 to Wells Fargo General Checking.
- b. Approve updated Facilities Manager Employment Agreement.

8. USE REQUESTS:

- |  |                           |
|--|---------------------------|
| a. Salinas Crusaders   | Car Club Anniversary      |
| b. Kathy Marci   | Wedding                   |
| c. Liliana D. Garcia   | Baptism                   |
| d. Martin Castellanos [Park]   | Picnic                    |
| e. UCCE Monterey County 4-H Program  | 10/30 Informational Event |
| f. UCCE Monterey County 4-H Program: Possible approval final draft of MOU. |                           |

9. FUNCTION RECAP:

10. NEW BUSINESS:

- a. CA State COVID Relief Funding.
- b. Discuss future projects.

11. CONTINUED BUSINESS:

- a. Spreckels Memorial Park Restroom ADA Upgrade Project: Review Invoices and Change Orders.
- b. CSDA Special Districts Leadership Academy: Report from Director Chang.

12. REGULAR MONTHLY FACILITIES REPORTS:

- a. Review of Building/Equipment Inspection Report.
- b. Review of Park Operations and Safety Report

13. FUTURE AGENDA ITEMS:

- a. Repurpose Racquetball Court Structure.
- b. Spreckels 4<sup>th</sup> of July Celebration 2022.

14. ADJOURN REGULAR MEETING: Next meeting Wednesday November 3, 2021 5:30 PM.

**2021 Meeting Dates: January 13, February 3, March 3, April 7, May 5, June 2, July 7, August 4, September 1, October 6, November 3, December 1**

**ADA COMPLIANCE**

**In compliance with the American Disabilities Act (ADA), disabled individuals requiring special accommodations to access, attend, or participate in District Board meetings, should contact the District Administrative Office, [831] 455-7855. To ensure that your request is granted please notify this office at least one business day prior to the scheduled public meeting.**

**In Compliance with Government Code section 54957.5, non-exempt writings that are distributed to a majority or all of the Board in advance of a meeting, may be viewed at Spreckels Veterans Memorial Building, 5<sup>th</sup> and Llano Streets, Spreckels, CA 93962, or at the scheduled meeting. In addition, if you would like a copy of any record related to an item on the agenda, please contact the District during normal business hours. Email requests please use spreckelsmd.main@gmail.com.**

**Certification**

I, Paul J. Ingram, General Manager/Board Clerk for Spreckels Memorial District, do hereby declare that the foregoing agenda was posted at least (72) hours prior to the October 6, 2021 Regular Meeting of the District Board of Directors scheduled for 6:30 pm at Spreckels Veterans Memorial Building, 5<sup>th</sup> and Llano Streets Spreckels, CA 93962

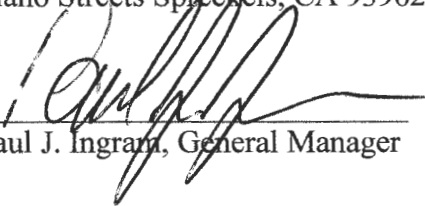
  
 \_\_\_\_\_  
 Paul J. Ingram, General Manager

Date 9/29/2021

**To download the full agenda packet, please go to [www.spreckelsmd.specialdistrict.org](http://www.spreckelsmd.specialdistrict.org) and click on the meeting date. Click on the link to the agenda.**

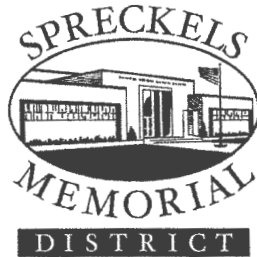

Spreckels Memorial District  
**MINUTES OF THE REGULAR MEETING OF THE BOARD OF DIRECTORS**  
**Wednesday September 8, 2021 5:30 pm**  
 Spreckels Veterans Memorial Building, 5<sup>th</sup> & Llano, Spreckels, CA 93962

1. CALL TO ORDER:

*The meeting was called to order at 5:31 pm.*

2. PLEDGE OF ALLEGIANCE:

3. ROLL CALL & ESTABLISHMENT OF QUORUM:

Rick Magno, President  
 Walan Chang, Vice-President  
 David Kuhlmann, Director  
 Jill Kramm, Director  
 Saren Pierson, Secretary

*Present: Magno, Chang, Kuhlmann, Kramm, Pierson*  
*Absent: None*

**QUORUM ESTABLISHED**

4. PUBLIC COMMENTS:

5. APPROVAL OF MINUTES:

a. SMD Regular Board Meeting August 11, 2021

*With Item 11.c. amended to read "SUSD agrees to pay for damages to SMD property and improvements, such as restriping of lot," motion to approve [Pierson] 2<sup>nd</sup> [Chang].*

*Ayes: Magno, Chang, Kuhlmann, Kramm, Chang*  
*Noes: None*

**MOTION CARRIED**

6. BUSINESS MANAGER'S REPORT:

a. Financial Reports February.

1. Fund Balances as of 9/8/2021
2. Budget FY 2021 FYTD to 8/31/2021
3. Review of Deposits: County Fund 668 July [Period 1]
4. Review of Deposits: Wells Fargo General Checking August.

- 5. Review of Wells Fargo Bank Statements/Reconciliations July 2021.
- 6. Review of Expenditures July 2021

7. ACTION ITEMS: DISCUSSION AND POSSIBLE APPROVAL

- a. Approve updated Facilities Manager Employment Agreement.

*Item tabled pending committee meeting with Directors Kramm and Chang.*

- b. Resolution 2021-02: Resolution to Adopt Budget FY 2021-22.

*Motion to adopt budget [Pierson] 2<sup>nd</sup> [Kuhlmann]  
 Ayes: Magno, Chang, Kuhlmann, Kramm, Pierson  
 Noes: None*

**MOTION CARRIED**

8. USE REQUESTS:

- a. Mo. Co. 4-H Youth Program Monthly Meetings [Hall]
- b. Sign With Us 3 Weekly Meeting
- c. Church Bros. Farms Christmas Party
- d. Cub Scout Pack 60 Pack Meetings
- e. Car Show Kustoms Car Club

*Kustoms Car Show must inquire with County Special Events Permit Coordinator about spectator parking on Spreckels Town Streets. Tentatively scheduled a special meeting for September 22 to approve event pending permitting issues resolved.*

*Motion [Chang] 2<sup>nd</sup> [Pierson] to approve Sign With Us 3 for a year of operation at the rental cost of 10% of their gross receipts.*

*Ayes: Magno, Chang, Kramm, Kuhlmann, Pierson  
 Noes: None*

**MOTION CARRIED**

*Motion to approve Cub Scout Pack 60 [Chang] 2<sup>nd</sup> [Kuhlmann].*

*Ayes: Magno, Chang, Kramm, Kuhlmann, Pierson  
 Noes: None*

**MOTION CARRIED**

9. FUNCTION RECAP:

10. NEW BUSINESS:

11. CONTINUED BUSINESS:

- a. Spreckels Memorial Park Restroom ADA Upgrade Project: Review Invoices.

*Also reviewed change order for plastering to straighten out exposed block walls. Approved but excluding janitor closet area.*

b. CSDA Annual Conference and Exhibitors Showcase: General Manager’s Report

12. REGULAR MONTHLY FACILITIES REPORTS:

- a. Review of Building/Equipment Inspection Report.
- b. Review of Park Operations and Safety Report

13. FUTURE AGENDA ITEMS:

*Racquetball Court repurposing.*

14. ADJOURN REGULAR MEETING: Next meeting Wednesday October 6, 2020 7:30 PM.

*The meeting was adjourned at 7:04 pm.*

*2021 Meeting Dates: January 13, February 3, March 3, April 7, May 5, June 2, July 7, August 4, September 1, October 6, November 3, December 1*

Respectfully submitted,

Approved date \_\_\_\_\_

\_\_\_\_\_  
Paul J. Ingram, General Manager

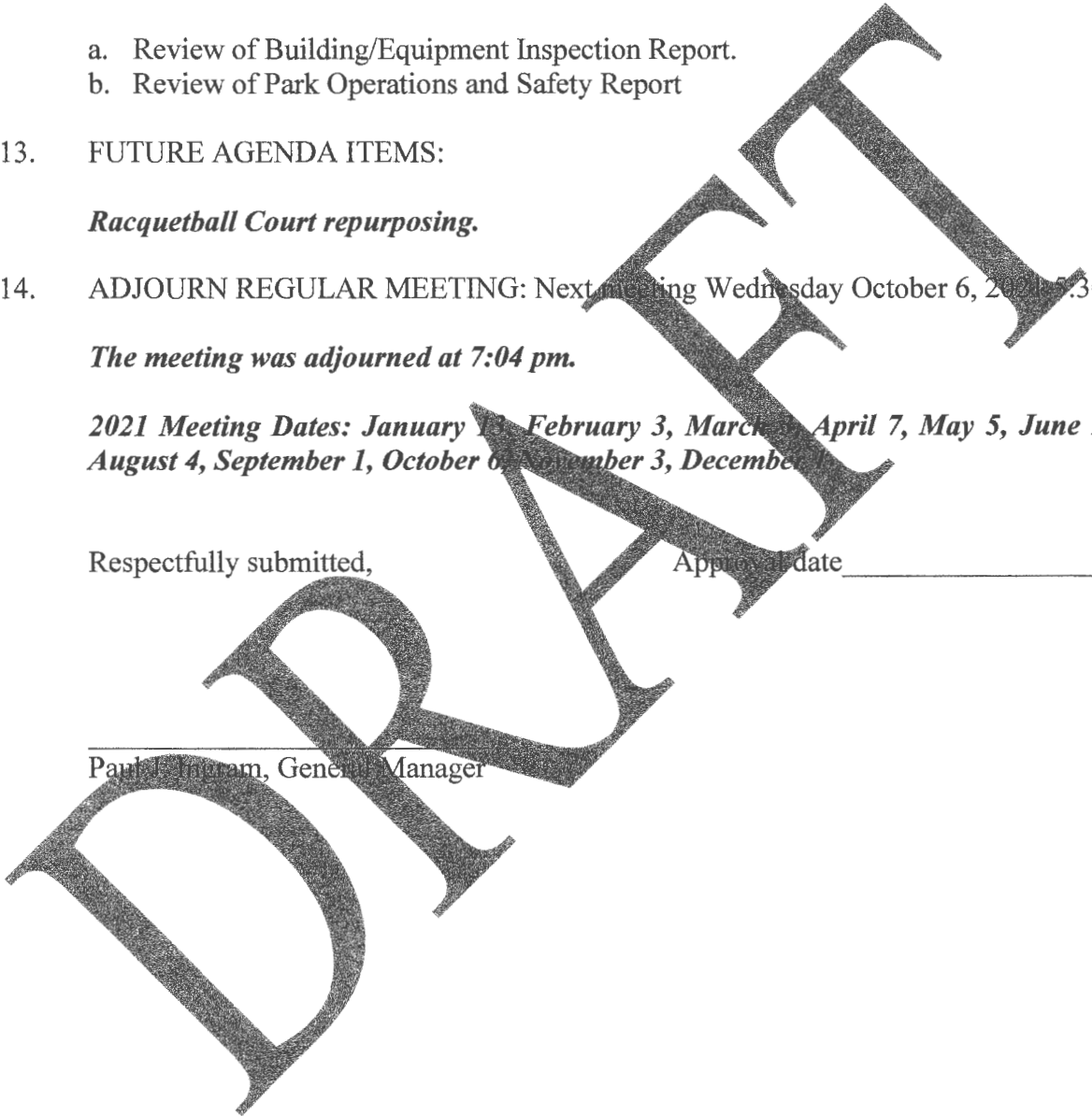

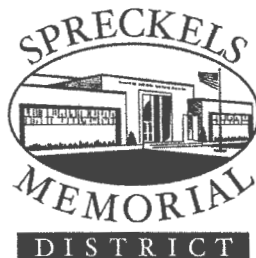

Spreckels Memorial District  
**MINUTES OF THE SPECIAL MEETING OF THE BOARD OF DIRECTORS**  
**Wednesday September 21, 2021 5:30pm**  
 Spreckels Veterans Memorial Building, 5<sup>th</sup> & Llano, Spreckels, CA 93962

1. CALL TO ORDER:

*The meeting was called to order by Vice-President Chang at 5:30 pm.*

2. ROLL CALL & ESTABLISHMENT OF QUORUM:

Rick Magno, President  
 Walan Chang, Vice-President  
 David Kuhlmann, Director  
 Jill Kramm, Director  
 Saren Pierson, Secretary

*Present: Chang, Kuhlmann, Pierson*  
*Absent: Magno, Kramm*

**QUORUM ESTABLISHED**

3. PUBLIC COMMENTS:

*None*

4. ACTION ITEM DISCUSSION AND POSSIBLE APPROVAL

a. Use Request: Labor Kustoms Car Club Show Saturday November 6, 2021

***Motion to approve event pending approval or non-requirement for Special Event or Encroachment Permit from County Special Event Task Force [Pierson] 2<sup>nd</sup> [Kuhlmann].***

***Ayes: Chang, Kuhlmann, Pierson***  
***Noes: None***

**MOTION CARRIED**

5. ADJOURN MEETING: Next Regular Meeting: October 6, 2021.

*Meeting was adjourned at 6:00 pm.*

Respectfully submitted,

Approval date \_\_\_\_\_

\_\_\_\_\_  
Paul J. Ingram, General Manager

DRAFT



**SPRECKELS MEMORIAL DISTRICT FUND  
BALANCES AS OF 10/6/2021 WITH  
TOMBLESON 9/30 INVOICE PAID**

<b>COUNTY FUND 668</b>	<b>\$ 63,081.88</b>
<b>WELLS FARGO</b>	
<b>GENERAL CHECKING</b>	<b>\$ 79,920.70</b>
<b>WELLS FARGO</b>	
<b>PAYROLL CHECKING</b>	<b><u>\$ 1,165.26</u></b>
<b>TOTAL</b>	<b>\$144,167.84</b>
<b>BALANCE TOMBLESON</b>	
<b>CONTRACT</b>	<b><u>&lt;\$133,796.55&gt;</u></b>
<b>BALANCE BEFORE DEC.</b>	
<b>TAX ROLLS</b>	<b>\$ 10,371.29</b>
<b>DEC. TAX ROLLS [12/20]</b>	<b>\$ 141,735.01</b>
<b>JAN. TAX ROLLS [1/20]</b>	<b>\$ 18,489.88</b>
<b>COVID RELIEF [1/7]</b>	<b><u>\$ 9,000.00</u></b>
<b>TOTAL 2/1</b>	<b>\$ 179,596.18</b>

Spreckels Memorial District  
Adopted Budget FYTD to 9/30/2021

Income	Budget	FYTD		
July 4th	\$10,000.00		\$10,000.00	0.00%
Memorial Building & Park rent	\$20,000.00	\$7,605.00	\$12,395.00	38.03%
<b>Sub Total</b>	<b>\$30,000.00</b>	<b>\$7,605.00</b>	<b>\$22,395.00</b>	<b>25.35%</b>
Per Capita Grant	\$177,960.00	\$177,960.00	\$0.00	100.00%
Property Tax	\$235,000.00		\$235,000.00	0.00%
Special Assessment	\$44,500.00		\$44,500.00	0.00%
Interest on Pooled Investments	\$2,000.00		\$2,000.00	0.00%
<b>Sub Total</b>	<b>\$459,460.00</b>	<b>\$0.00</b>	<b>\$459,460.00</b>	<b>0.00%</b>
<b>Total Income</b>	<b>\$489,460.00</b>	<b>\$7,605.00</b>	<b>\$481,855.00</b>	<b>1.55%</b>
<b>Expense</b>				
<b>Salaries</b>				
Pay Roll Expenses	\$90,000.00	\$23,128.09	\$66,871.91	25.70%
<b>Employee Benefits</b>				
Workers Comp	\$2,500.00	-\$256.76		-10.27%
<b>Total Salary and Benefits</b>	<b>\$92,500.00</b>	<b>\$22,871.33</b>	<b>\$69,628.67</b>	<b>24.73%</b>
<b>Operations Budget</b>				
<b>4th of July</b>	<b>\$10,000.00</b>		<b>\$10,000.00</b>	<b>0.00%</b>
<b>Professional Services</b>				
Audits	\$8,000.00		\$8,000.00	0.00%
Administration Fees	\$3,000.00	\$423.00	\$2,577.00	14.10%
Advertising	\$1,200.00	\$116.25	\$1,083.75	9.69%
Legal Services	\$2,000.00	\$638.00	\$1,362.00	31.90%
Parcel Management	\$3,875.00	\$3,800.00	\$75.00	98.06%
Bank Fees	\$50.00		\$50.00	0.00%
Property Tax	\$450.00		\$450.00	0.00%
<b>Sub Total</b>	<b>\$18,575.00</b>	<b>\$4,977.25</b>	<b>\$13,597.75</b>	<b>26.80%</b>
<b>Education</b>				
Board and Staff Education	\$1,500.00	\$488.50	\$1,011.50	32.57%
Dues and Subscriptions	\$2,500.00	\$12.00	\$2,488.00	0.48%
<b>Sub Total</b>	<b>\$4,000.00</b>	<b>\$500.50</b>	<b>\$3,499.50</b>	<b>12.51%</b>
<b>MAINTENANCE</b>				
Building Materials	\$1,200.00	\$180.21	\$1,019.79	15.02%
Electrical Repairs Hall	\$1,000.00		\$1,000.00	0.00%
Electrical Repairs Park	\$250.00		\$250.00	0.00%
Equipment Purchase	\$1,000.00	\$549.52	\$450.48	54.95%
Equipment Rental	\$500.00		\$500.00	0.00%
Power Equipment Repairs	\$200.00		\$200.00	0.00%

Spreckels Memorial District  
Adopted Budget FYTD to 9/30/2021

Plumbing Repairs Hall	\$250.00		\$250.00	0.00%
Plumbing Repairs Park	\$250.00		\$250.00	0.00%
HVAC	\$2,000.00		\$2,000.00	0.00%
Equipment Maint & Repairs Hall	\$1,000.00		\$1,000.00	0.00%
Equipment Maint & Repairs Park	\$1,000.00	\$58.29	\$941.71	5.83%
Sprinkler Supplies	\$500.00	\$575.12	-\$75.12	115.02%
Sprinkler System Repairs	\$850.00		\$850.00	0.00%
Park Plants	\$250.00		\$250.00	0.00%
Fuel	\$850.00	\$311.59	\$538.41	36.66%
Pest Contol	\$600.00	\$130.00	\$470.00	21.67%
Landscape Maintenance Contract	\$25,000.00	\$6,240.00	\$18,760.00	24.96%
Tree Maintenance	\$2,500.00		\$2,500.00	0.00%
Turf Treatment	\$6,500.00	\$200.00	\$6,300.00	3.08%
Water Treatment	\$1,400.00	\$224.78	\$1,175.22	16.06%
<b>Sub Total</b>	<b>\$47,100.00</b>	<b>\$8,469.51</b>	<b>\$38,630.49</b>	<b>17.98%</b>
<b>Utilities</b>				
PG&E Park	\$5,000.00	\$687.34	\$4,312.66	13.75%
PG&E Hall	\$12,000.00	\$2,693.69	\$9,306.31	22.45%
Water / Park	\$20,000.00	\$6,699.96	\$13,300.04	33.50%
Water / Hall	\$3,500.00	\$1,040.43	\$2,459.57	29.73%
Sewer	\$1,300.00	\$330.46	\$969.54	25.42%
Telephone and Internet	\$5,500.00	\$1,012.92	\$4,487.08	18.42%
<b>Sub Total</b>	<b>\$47,300.00</b>	<b>\$12,464.80</b>	<b>\$34,835.20</b>	<b>26.35%</b>
<b>Supplies</b>				
Janitorial Supplies	\$4,000.00	\$816.95	\$3,183.05	20.42%
<b>Sub Total</b>	<b>\$4,000.00</b>	<b>\$816.95</b>	<b>\$3,183.05</b>	<b>20.42%</b>
<b>Office/Operating Expenses</b>				
Office Supplies	\$500.00	\$52.43	\$447.57	10.49%
Office Equipment	\$100.00		\$100.00	0.00%
Post Office Box	\$225.00		\$225.00	0.00%
Website	\$600.00		\$600.00	0.00%
Postage and Delivery	\$55.00	\$58.00	-\$3.00	105.45%
<b>Sub Total</b>	<b>\$1,480.00</b>	<b>\$110.43</b>	<b>\$1,369.57</b>	<b>7.46%</b>
<b>Insurance</b>				
General Liability / Property Insurance	\$3,000.00	\$8,757.83	-\$5,757.83	291.93%
<b>Sub Total</b>	<b>\$3,000.00</b>	<b>\$17,515.66</b>	<b>-\$14,515.66</b>	<b>583.86%</b>
<b>Total Operations</b>	<b>\$227,955.00</b>	<b>\$67,726.43</b>	<b>\$160,228.57</b>	<b>29.71%</b>
<b>Capital Expense</b>				
Building			\$0.00	#DIV/0!
Park	\$370,000.00	147123.92	\$222,876.08	39.76%
<b>Sub Total</b>	<b>\$370,000.00</b>	<b>147123.92</b>		<b>39.76%</b>
<b>Emergency Reserve</b>	<b>-\$108,145.00</b>			
<b>Total Expense</b>	<b>\$489,810.00</b>	<b>\$214,850.35</b>	<b>\$274,959.65</b>	<b>43.86%</b>

Fund 668 - Spreckels Memorial District  
 Account Type Liability  
 BSA/Obj/Rev B-2530 - Assets Held as Agency for Others  
 Sub BSA/Obj/Rev 4010 - Current Secured

Transaction ID	Jrnl Doc Ref (Code,Dept,ID)	Transaction Date	Description	Beginning Balance	Debits	Credits	Ending Balance
JV,1110,PTAX56_21_CS		06/30/2021	Curr Sec - June 2021		0.00	(983.41)	
<b>Total for Sub-BSA 4010 - Current Secured</b>				(1,882,198.94)	0.00	(983.41)	(1,883,182.35)

Sub BSA/Obj/Rev 4015 - Current Unsecured

Transaction ID	Jrnl Doc Ref (Code,Dept,ID)	Transaction Date	Description	Beginning Balance	Debits	Credits	Ending Balance
JV,1110,PTAX57_21_CU		06/30/2021	Curr Unsec - June 2021		60.45	0.00	
<b>Total for Sub-BSA 4015 - Current Unsecured</b>				(72,996.62)	60.45	0.00	(72,936.17)

Sub BSA/Obj/Rev 4025 - Prior Secured

Transaction ID	Jrnl Doc Ref (Code,Dept,ID)	Transaction Date	Description	Beginning Balance	Debits	Credits	Ending Balance
JV,1110,PTAX51_21_PRSEC		06/30/2021	Prior Secured - June 2021		0.00	(107.09)	
<b>Total for Sub-BSA 4025 - Prior Secured</b>				(37,227.69)	0.00	(107.09)	(37,334.78)

Sub BSA/Obj/Rev 4030 - Prior Unsecured

Transaction ID	Jrnl Doc Ref (Code,Dept,ID)	Transaction Date	Description	Beginning Balance	Debits	Credits	Ending Balance
					0.00	0.00	
<b>Total for Sub-BSA 4030 - Prior Unsecured</b>				(764.46)	0.00	0.00	(764.46)

Sub BSA/Obj/Rev 4035 - Current Supplemental

Transaction ID	Jrnl Doc Ref (Code,Dept,ID)	Transaction Date	Description	Beginning Balance	Debits	Credits	Ending Balance
JV,1110,PTAX52_21_SUPPL		07/09/2021	Suppl - June 2021		0.00	(532.99)	

**Fund** 668 - Spreckels Memorial District  
**Account Type** Liability  
**BSA/Obj/Rev** B-2530 - Assets Held as Agency for Others  
**Sub BSA/Obj/Rev** 4035 - Current Supplemental

Transaction ID	Jrnl Doc Ref (Code,Dept,ID)	Transaction Date	Description	Beginning Balance	Debits	Credits	Ending Balance
JV,1110,PTAX52B_21_SUPPL		07/09/2021	Rev Suppl - June 2021		532.99	0.00	
JV,1110,PTAX52C_21_SUPPL		06/30/2021	Suppl - June 2021		0.00	(532.99)	

**Total for Sub-BSA 4035 - Current Supplemental** (32,663.93) 532.99 (1,065.98) (33,196.92)

**Sub BSA/Obj/Rev** 4040 - Prior Supplemental

Transaction ID	Jrnl Doc Ref (Code,Dept,ID)	Transaction Date	Description	Beginning Balance	Debits	Credits	Ending Balance
					0.00	0.00	

**Total for Sub-BSA 4040 - Prior Supplemental** (1,976.49) 0.00 0.00 (1,976.49)

**Sub BSA/Obj/Rev** 4090 - Other Property Taxes

Transaction ID	Jrnl Doc Ref (Code,Dept,ID)	Transaction Date	Description	Beginning Balance	Debits	Credits	Ending Balance
					0.00	0.00	

**Total for Sub-BSA 4090 - Other Property Taxes** (4,602.28) 0.00 0.00 (4,602.28)

**Sub BSA/Obj/Rev** 5030 - HOPTR

Transaction ID	Jrnl Doc Ref (Code,Dept,ID)	Transaction Date	Description	Beginning Balance	Debits	Credits	Ending Balance
					0.00	0.00	

**Total for Sub-BSA 5030 - HOPTR** (10,442.76) 0.00 0.00 (10,442.76)

**Sub BSA/Obj/Rev** 5325 - Other In Lieu Revenues

Transaction ID	Jrnl Doc Ref (Code,Dept,ID)	Transaction Date	Description	Beginning Balance	Debits	Credits	Ending Balance

Fund	668 - Spreckels Memorial District						
Account Type	Liability						
BSA/Obj/Rev	B-2530 - Assets Held as Agency for Others						
Sub BSA/Obj/Rev	5415 - Special Assessments						
Transaction ID	Jrnl Doc Ref (Code,Dept,ID)	Transaction Date	Description	Beginning Balance	Debits	Credits	Ending Balance
					0.00	0.00	
<b>Total for Sub-BSA 5415 - Special Assessments</b>				<b>(475,150.64)</b>	<b>0.00</b>	<b>0.00</b>	<b>(475,150.64)</b>
Sub BSA/Obj/Rev	No Sub-BSA Specified						
Transaction ID	Jrnl Doc Ref (Code,Dept,ID)	Transaction Date	Description	Beginning Balance	Debits	Credits	Ending Balance
JVA,1110,INTALLOCC42021-07		06/30/2021	InterestAllocation 4th Qtr2020-21		0.00	(378.90)	
<b>Total for Sub-BSA No Sub-BSA Specified</b>					<b>0.00</b>	<b>(378.90)</b>	<b>2,350,488.45</b>
<b>Total for B-2530 - Assets Held as Agency for Others</b>				<b>(236,423.30)</b>	<b>0.00</b>	<b>(378.90)</b>	<b>(236,802.20)</b>
<b>Total for Fund 668 - Spreckels Memorial District</b>				<b>(0.00)</b>	<b>378.90</b>	<b>(378.90)</b>	<b>(0.00)</b>
<b>Grand Total</b>				<b>(0.00)</b>	<b>378.90</b>	<b>(378.90)</b>	<b>(0.00)</b>

Deposit Summary

Spreckels Memorial District

Summary of Deposits to Wells General Checking 2 on 09/02/2021

<b>Chk No.</b>	<b>PmtMethod</b>	<b>Rcd From</b>	<b>Memo</b>	<b>Amount</b>
		CA Department of Parks & Recreation	Per Capita Grant	177,952.00
<b>Less Cash Back:</b>				
<b>Deposit Total:</b>				<b>177,952.00</b>

## Deposit Summary

Spreckels Memorial District

Summary of Deposits to Wells General Checking 2 on 09/02/2021

<b>Chk No.</b>	<b>PmtMethod</b>	<b>Rcd From</b>	<b>Memo</b>	<b>Amount</b>
		Paul Ingram	CSDA conference Taste of the City Li...	60.00
<b>Less Cash Back:</b>				
<b>Deposit Total:</b>				<b>60.00</b>



## Deposit Summary

Spreckels Memorial District

Summary of Deposits to Wells General Checking 2 on 09/08/2021

<b>Chk No.</b>	<b>PmtMethod</b>	<b>Rcd From</b>	<b>Memo</b>	<b>Amount</b>
		Salinas Valley AA	Building Rent	950.00
		Church Brothers LLC	LD&C Deposits	500.00
		Vanessa Hill	LD&C Deposits	200.00
		Xolon Salinas Heritage Foundation	Meeting Room Rent	100.00
		Emmanuel Garcia	LD&C Deposits	300.00
		Antonio Ojeda	LD&C Deposits	500.00
<b>Less Cash Back:</b>				
<b>Deposit Total:</b>				<b>2,550.00</b>

# SPRECKELS MEMORIAL DISTRICT

P.O. BOX 7266 \* SPRECKELS, CA 93962

## USE REQUEST FOR SPRECKELS MEMORIAL BUILDING AND/OR FACILITIES

SALINAS CRUSADERS

Ernie Fuentes

Organization Name

Contact Person

1105 RANCHERO DR

SALINAS CA 93905

Mailing Address

City & Zip Code

Work Telephone #

Home Telephone #

Cell Phone #

DATE OF FUNCTION:

OCT, 9 2021

Day of Week, Date & Year

TYPE OF FUNCTION:

CAR CLUB ANNIVERSARY

Circle areas of use required:

Kitchen

Barbeque Room

Bar Facilities:  Yes - No

Meeting Room

Banquet Room

Dancing:  Yes - No

Auditorium

Other STAGE

PA System:  Yes - No

HOURS OF USE: 5pm to 12am

NUMBER OF GUESTS 220

\* PLEASE NOTE: No guests will be allowed in building until contract starting time. Loss/Damage and Cleaning Deposit is due within 7 days after contract approval. Balance of rent is due 10 days prior to function.

SIGNATURE [Signature]

DATE 3-9-21

### FOR OFFICE USE ONLY:

Rental Fee

\$1500

LD&C Deposit

\$500

Approval Date

Disapproved on

# of Security Required

4

Postponed

DATE DEPOSIT RECEIVED

CASH

CHECK #

DATE BALANCE RECEIVED

9-28-21

CASH

CHECK #

-1500

DATE RETURNED LD&C MAILED

AMOUNT \$

CHECK #

# SPRECKELS MEMORIAL DISTRICT

P.O. BOX 7266 \* SPRECKELS, CA 93962

## USE REQUEST FOR SPRECKELS MEMORIAL BUILDING AND/OR FACILITIES

Organization Name \_\_\_\_\_ Contact Person Kathy Moran

Mailing Address 24 Sepulveda Cir Salinas 93906  
City & Zip Code

Work Telephone # \_\_\_\_\_ Home Telephone # Same Cell Phone # (831) 229-4233

DATE OF FUNCTION: Dec 26<sup>th</sup> 2021  
 Day of Week, Date & Year

TYPE OF FUNCTION: Wedding

Circle areas of use required:

Kitchen	Barbeque Room	Bar Facilities:	Yes - No
Meeting Room	Banquet Room	Dancing:	Yes - No
Auditorium	Other _____	PA System:	Yes - No

HOURS OF USE: 1pm to 8pm NUMBER OF GUESTS 90

PLEASE NOTE: No guests will be allowed in building until contract starting time. Loss/Damage and Cleaning Deposit is due within 7 days after contract approval. Balance of rent is due 10 days prior to function.

SIGNATURE Kathy Moran DATE 9/29/21

FOR OFFICE USE ONLY:

Rental Fee	\$ <u>1500</u>	LD&C Deposit	\$ <u>500</u>
Approval Date	_____	Disapproved on	_____
# of Security Required	_____	Postponed	_____
DATE DEPOSIT RECEIVED	_____	CASH _____	CHECK # _____
DATE BALANCE RECEIVED	_____	CASH _____	CHECK # _____
DATE RETURNED LD&C MAILED	_____	AMOUNT \$ _____	CHECK # _____

# SPRECKELS MEMORIAL DISTRICT

P.O. BOX 7266 \* SPRECKELS, CA 93962

## USE REQUEST FOR SPRECKELS MEMORIAL BUILDING AND/OR FACILITIES

Liliana D. Garcia  
 Organization Name \_\_\_\_\_ Contact Person \_\_\_\_\_

1044 Saint George Dr. Salinas Ca 93905  
 Mailing Address \_\_\_\_\_ City & Zip Code \_\_\_\_\_

\_\_\_\_\_ 831-256-5817  
 Work Telephone # \_\_\_\_\_ Home Telephone # \_\_\_\_\_ Cell Phone # \_\_\_\_\_

DATE OF FUNCTION: Jan 9th 2022  
 Day of Week, Date & Year

TYPE OF FUNCTION: Baptism

Circle areas of use required:

<u>Kitchen</u>	Barbeque Room	Bar Facilities: <u>Yes</u> - No
Meeting Room	<u>Banquet Room</u>	Dancing: <u>Yes</u> - No
<u>Auditorium</u>	Other _____	PA System: Yes - <u>No</u>

HOURS OF USE: 4 to 11 NUMBER OF GUESTS 160

PLEASE NOTE: No guests will be allowed in building until contract starting time. Loss/Damage and Cleaning Deposit is due within 7 days after contract approval. Balance of rent is due 10 days prior to function.

SIGNATURE Liliana D. Garcia DATE 9-18-2021

FOR OFFICE USE ONLY:

Rental Fee	\$ <u>1500</u>	LD&C Deposit	\$ <u>500</u>
Approval Date	_____	Disapproved on	_____
# of Security Required	_____	Postponed	_____
DATE DEPOSIT RECEIVED	_____	CASH _____	CHECK # _____
DATE BALANCE RECEIVED	_____	CASH _____	CHECK # _____
DATE RETURNED LD&C MAILED	_____	AMOUNT \$ _____	CHECK # _____



**Spreckels Memorial Park USE AGREEMENT**

**Note:** A Cleanup/Damage fee will be charged if the park is not left clean and trash hauled away or put in receptacles immediately following the event, or if damage occurs to the park. The fee will be taken from the Deposit.

**Note:** All reservations can be made on a first come, first serve basis. Residents can make their reservation at any time in advance however **all areas become available to non-residents 59 days in advance. Residents should secure their reservation 60 days in advance to insure availability.**

Date of Event: 10/17/2021 Time (including setup & cleanup) 11-6 pm  
 Responsible party: Martin Castellanos Organization: \_\_\_\_\_  
 Fax/Email: \_\_\_\_\_ Telephone: (702) 793-3846

Renter agrees to pay the following reservation fee per day:

AREA	RESIDENT FEE	NON-RESIDENT	DEPOSIT (ALL)
(1) Large Rotunda Area	\$25	\$75	\$100
(2) Smaller Area/playground	\$15	\$45	\$100



All other areas in the park are open to the general public and cannot be reserved. They are useable on a first-come, first-serve basis.

JUMP HOUSE FEE (per unit)	\$10	\$30	
Electricity Fee	\$10	\$30	

+

**Spreckels Memorial Park USE AGREEMENT**

Area reserved: large rotunda area Fee: \_\_\_\_\_  
 Deposit Deposit: \$100  
 # of Jump Houses: 2 Fee: \_\_\_\_\_  
 Will you require electricity: NO Fee: \_\_\_\_\_  
 Total Charged: \_\_\_\_\_ Check # Received: \_\_\_\_\_  
 Responsible Party (Signature): Nanette Gustafson

Date Received: \_\_\_\_\_  
 Date signed: 10/5/2021

Residents must provide proof of residency at time of rental. Acceptable proof of residency is **driver's license, utility bill or tax bill** within the **SPRECKELS MEMORIAL DISTRICT**. The rental of a PO BOX in Spreckels is **NOT** proof of residency.

Proof of residency provide (Yes and type provided or No): \_\_\_\_\_  
 Resident Address: \_\_\_\_\_  
 Mailing Address for deposit refund: \_\_\_\_\_

- Blocking off parking space / placing barricades / cones are prohibited. Blocking residential driveways is also prohibited.
- **NO AMPLIFIED MUSIC** is allowed.
- **NO INTOXICANTS OF ANY TYPE INCLUDING ALCOHOL** are allowed per county ordinance section 11.30.010.
- **RENTER** agrees to bag and remove all refuse created by the use of the facility. While there are refuse receptacles in the park, the **RENTER** agrees not to overfill receptacles or leave bagged refuse at SPRECKELS MEMORIAL PARK. **RENTER** agrees to clean the facility, if necessary, and to return the facility in the same condition as it was prior to the rental period.
- **RENTER** agrees to reimburse the SPRECKELS MEMORIAL DISTRICT for any costs which result from any damage done to the facility during the rental period. The **SPRECKELS MEMORIAL DISTRICT** will provide an itemized cost of repairing damage, or the cost to replace **SPRECKELS MEMORIAL DISTRICT** property.
- **SPRECKELS MEMORIAL DISTRICT** will not be held responsible for loss, theft or damage to equipment or articles.
- Repeat reservations of any given group will be contingent upon care of property and observance of rules and general policies, and availability of the park.
- Owners of pets must clean-up after them.

Renter acknowledges these rules (signature/date): \_\_\_\_\_

Office use: \_\_\_\_\_ Explanation: \_\_\_\_\_  
 Damage fee: \_\_\_\_\_  
 Clean up fee: \_\_\_\_\_  
 Deposit refund amount: \_\_\_\_\_ Date: \_\_\_\_\_ Park Personnel signature: \_\_\_\_\_



### Facilities Use Agreement with the 4-H Program

The purpose for use is for the 4-H Program, Leaders Council and Community Clubs to hold monthly 4-H meetings, trainings or 4-H events at Spreckels Veterans Memorial Building.

**Effective date:** From Date signed to June 30, 2022

**Meeting Dates:** Various

**Fees:** There will be no charge for monthly meetings or trainings. (see exception below) Clubs that are interested in holding fundraisers or special events, are to contact the SVMB staff directly for a use fee.

Official Notices and communications regarding this Agreement shall be sent to:

**Applicant Organization Name:** UC Regents c/of UCCE Monterey County 4-H Program

**Applicant Responsible for communication:** Lorin Hofmann-Lurz, 4-H Program Representative

**Applicant Responsible Signing Person:** Dr. Maria de la Fuente, County Director, UCCE offices

**Applicant address:** 1432 Abbott, Salinas, CA 93901

**Applicant Phone:** (831) 759-7360

### **Spreckels Veteran's Memorial Building Contact Information:**

Joseph Velasquez, Facilities Manager

Office: [831] 455-2022

Mobile: [831] 756-2269

Email: jvelasquez0608@gmail.com

Paul J. Ingram, General Manager

Office: [831] 455-7855

Email: spreckelsmd.main@gmail.com

### **Agreement for Use**

1. **Facility use.** The 4-H Program is entitled to hold monthly meetings or trainings at the building at no charge. **The Leader's Council meetings, or other large gatherings that require tables and chairs to serve over 30 people, will be charged a fee of \$25 per use. Notifications of these meetings will come via email to the SVMB. This will be billed quarterly.**
2. **Liability Insurance.** At all times, the Regents of the University of California shall carry public liability and property damage insurance in the amount of \$1,000,000 (one million dollars) naming Spreckels Memorial District [SMD] as additional insured. This insurance policy applies to the Monterey County 4-H Program and University of California, Division of Agriculture & Natural Resources and Monterey County Cooperative Extension.

Spreckels Memorial District • P.O. Box 7266 • Spreckels, CA 93962

Park & Memorial Building Rental (831) 455-2022 • District Business (831) 455-7855

Email: spreckelsmd.main@gmail.com • www.spreckelsmd.specialdistrict.org

3. **Use dates.** The 4-H Program is to provide a written list of proposed dates of meetings. This is to be updated using a date at the bottom of the page. This list is to be shared with the SVMB staff.
4. **Safety.** Safety and security of all people and property is the number one priority at the SVMB facility. Regardless of the SVMB rules and requirements, any act or circumstance deemed unsafe by staff or Leadership must cease immediately upon notice. This includes but is not limited to; running, roughhousing, and rough use of fixtures, walls and structures both inside and outside the building.
5. **Kitchen.** When the kitchen is used, all counters and appliances shall be wiped clean, the refrigerator emptied of all 4H food & beverages, and the kitchen shall be cleared of all trash and debris at the end of the use.
6. **Garbage.** The representatives of 4-H must remove waste and recyclables from the premises after each use, including from bathrooms.
7. **Floors.** The floors must be swept after each use with brooms and/or dry mop. Spills should be absorbed with cloth, paper or other appropriate method, and damp rag used for sticky spills.
8. **Decorations.** Decorations may be attached to the walls with tape only. No staples, thumbtacks, pushpins or nails will be allowed. All decorations shall be removed from the facility after each use. Any signs placed in the neighborhood or elsewhere in town shall be removed as well.
9. **Furniture.** All benches, tables and chairs shall be returned to their pre-use locations.
10. **Bathrooms.** The wastebaskets in all bathrooms shall be emptied at the end of use.
11. **Pets/livestock.** Service Animals shall be under control at all times. No large livestock type animals are allow inside the building
12. **Parking.** Vehicles shall park in the designated parking lot and along the public street. Do not block driveways of the neighbors.
13. **Amplified music.** Amplified music shall be restricted to no higher than 80 decibels. All music shall cease at 10:00 PM. No audio or electronic items are included in the use of the facility with prior arrangements.
14. **Alcoholic beverages.** No alcoholic beverages are allowed with use of the facility by 4-H at any time.
15. **Smoking.** In compliance with state and local laws, no smoking is allowed in the facility at any time.







## CA STATE COVID-19 FISCAL RELIEF FOR SPECIAL DISTRICTS

- 2021 Budget Act appropriating \$100,000,000.00 one-time to provide fiscal relief to **independent special districts.**
- Mitigate effects of revenue loss or costs incurred due to COVID-19 emergency.
- Allocation Methodology: Each district base on its proportionate share of total costs and revenue losses incurred by all districts who apply for funding during the eligible periods.
- Revenue Losses: FY 2020-21 revenue compared to FY 2018-19 revenue

SMD FY 2018-19 Total Revenue:	<b>\$294,522.00</b>
SMD FY 2020-21 Total Revenue:	<b><u>- \$285,353.00</u></b>
Revenue Loss Eligible for Relief:	<b>\$ 9,169.00</b>

- Application: October 1 to October 15
- State completes application review and calculation: November 5
- Submit final calculations to State Controller's Office: November 12
- Submit final calculations to County Auditor-Controller: November 12
- SCO disburses payments to County Auditor-Controller: December 9
- County A-C disburses payment [within 30 days]: [by] January 7

# PAYMENT APPLICATION

**TO:** Spreckels Memorial District  
90 Fifth Street  
Spreckels CA 93962

**PROJECT NAME AND LOCATION:** Spreckels Mem Park Restroom ADA Upgrades  
60 Llano Ave.  
Spreckels CA 93962

**APPLICATION #** 3  
**PERIOD THRU:** 09/30/2021  
**OWNER PROJECT #:**

**Distribution to:**  
\_\_\_ OWNER  
\_\_\_ ARCHITECT  
\_\_\_ CONTRACTOR

**FROM:** TOMBLESON INCORPORATED  
PO BOX 1388  
SALINAS CA 93902

**ARCHITECT:** Central Coast Engineers, Inc.  
P.O. Box 2503  
Salinas CA 93902

**DATE OF CONTRACT:** 5/18/2021

## CONTRACTOR'S SUMMARY OF WORK

Application is made for payment as shown below.  
Continuation Page is attached

<b>1. CONTRACT AMOUNT</b>	342,875.00
<b>2. SUM OF ALL CHANGE ORDERS</b>	11,084.75
<b>3. CURRENT CONTRACT AMOUNT</b> (Line 1 + 2)	353,959.75
<b>4. TOTAL COMPLETED AND STORED</b> (Column G on Continuation Page)	231,750.75
<b>5. RETAINAGE:</b>	
A. 5% Of Completed Work (Columns D+ E on Continuation Page)	11,587.55
B. 0% of Material Stored (Colum F on Continuation Page)	0.00
Total Retainage (Line 5a + 5b or Column I on Continuation Page)	11,587.55
<b>6. TOTAL COMPLETED AND STORED LESS RETAINAGE:</b> (Line 4 minus Line 5 Total)	220,163.20
<b>7. LESS PREVIOUS CERTIFICATES FOR PAYMENT:</b>	146,314.02
<b>8. CURRENT PAYMENT DUE:</b>	73,849.18
<b>9. BALANCE TO FINISH:</b> Line 3 - Line 6	133,796.55

SUMMARY OF CHANGE ORDERS	ADDITIONS	DEDUCTIONS
Total changes approved in previous months	3650.75	0.00
Total approved this month	7434.00	0.00
TOTALS	11084.75	0.00
NET CHANGES	11,084.75	

Contractor's signature below: TOMBLESON INCORPORATED

CONTRACTOR:

By:  Date: 9/30/2021

State of:

County of:

Subscribed and sworn to before me this \_\_\_\_\_ day of \_\_\_\_\_

Notary Public:

My Commission Expires:

## ARCHITECT'S CERTIFICATION

Architect's signature below:

CERTIFIED AMOUNT: .....73,849.18

ARCHITECT: Central Coast Engineers, Inc.

By: \_\_\_\_\_ Date: \_\_\_\_\_

INSPECTOR: \_\_\_\_\_

By: \_\_\_\_\_ Date: \_\_\_\_\_

<b>PAYMENT APPLICATION DETAILS</b>		
<b>TO:</b> Spreckels Memorial District 90 Fifth Street Spreckels CA 93962	<b>PROJECT:</b> Spreckels Mem Park Restroom ADA Upgrades 60 Llano Ave. Spreckels CA 93962	<b>APPLICATION #:</b> 3 <b>PERIOD THRU:</b> 9/30/2021 <b>OWNER PROJECT #:</b> <b>DATE OF CONTRACT:</b> 5/18/2021
<b>FROM:</b> TOMBLESON INCORPORATED PO BOX 1388 SALINAS CA 93902	<b>ARCHITECT:</b> Central Coast Engineers, Inc. P.O. Box 2503 Salinas CA 93902	

A	B	C	D	E	F	G		H	I
Item Number - Description		Scheduled Value	Work Completed		Materials Presently Stored	Completed and Stored To Date	Total %	Balance To Finish	Retainage Value
			From Previous Application	This Period Value					
00 72 00	General Conditions	69,010.00	34,505.00	17,252.50	0.00	51,757.50	75.00	17,252.50	2,587.89
02 41 00	Concrete Demolition	14,950.00	11,212.50	0.00	0.00	11,212.50	75.00	3,737.50	560.63
02 41 19	Selective Demolition	26,709.00	26,709.00	0.00	0.00	26,709.00	100.00	0.00	1,335.45
03 31 00	Building Concrete	17,220.00	17,220.00	0.00	0.00	17,220.00	100.00	0.00	861.00
04 00 00	Masonry	9,500.00	9,500.00	0.00	0.00	9,500.00	100.00	0.00	475.00
06 10 00	Rough Carpentry	17,407.00	8,703.50	6,092.45	0.00	14,795.95	85.00	2,611.05	739.79
07 32 00	Slate Roofing	13,978.00	0.00	1,397.80	0.00	1,397.80	10.00	12,580.20	69.89
07 62 00	Sheet Metal Flasing and Trim	5,776.00	0.00	0.00	0.00	0.00	0.00	5,776.00	0.00
07 92 00	Joint Sealants	300.00	0.00	0.00	0.00	0.00	0.00	300.00	0.00
08 11 00	Metal Doors and Frames	4,356.00	2,178.00	0.00	0.00	2,178.00	50.00	2,178.00	108.90
08 31 16	Access Doors	214.00	0.00	0.00	0.00	0.00	0.00	214.00	0.00
08 70 00	Finish Hardware	2,304.00	1,152.00	0.00	0.00	1,152.00	50.00	1,152.00	57.60
09 29 00	Gypsum Drywall	17,239.00	0.00	12,929.25	0.00	12,929.25	75.00	4,309.75	646.46
09 67 16	Epoxy Flooring	12,701.00	0.00	0.00	0.00	0.00	0.00	12,701.00	0.00
09 91 00	Painting	5,700.00	0.00	0.00	0.00	0.00	0.00	5,700.00	0.00
10 14 00	Signage	858.00	592.02	265.98	0.00	858.00	100.00	0.00	42.90
10 21 13	Plastic Toilet Compartments	17,600.00	0.00	0.00	0.00	0.00	0.00	17,600.00	0.00
10 28 13	Toilet Accessories	1,753.00	0.00	0.00	0.00	0.00	0.00	1,753.00	0.00
22 00 00	Plumbing	67,000.00	34,840.00	20,770.00	0.00	55,610.00	83.00	11,390.00	2,780.50
23 30 00	Mechanical	3,000.00	0.00	0.00	0.00	0.00	0.00	3,000.00	0.00
26 00 00	Electrical	26,800.00	3,752.00	19,028.00	0.00	22,780.00	85.00	4,020.00	1,139.00
32 16 00	Site Concrete	8,500.00	0.00	0.00	0.00	0.00	0.00	8,500.00	0.00
90 00 01	PCO #1	3,650.75	3,650.75	0.00	0.00	3,650.75	100.00	0.00	182.54

**PAYMENT APPLICATION DETAILS**

**TO:** Spreckels Memorial District  
 90 Fifth Street  
 Spreckels CA 93962

**PROJECT:** Spreckels Mem Park Restroom ADA Upgrades  
 60 Llano Ave.  
 Spreckels CA 93962

**APPLICATION #:** 3  
**PERIOD THRU:** 9/30/2021  
**OWNER PROJECT #:**  
**DATE OF CONTRACT:** 5/18/2021

**FROM:** TOMBLESON INCORPORATED  
 PO BOX 1388  
 SALINAS CA 93902

**ARCHITECT:** Central Coast Engineers, Inc.  
 P.O. Box 2503  
 Salinas CA 93902

A	B	C	D	E	F	G		H	I
Item Number - Description		Scheduled Value	Work Completed		Materials Presently Stored	Completed and Stored To Date	Total %	Balance To Finish	Retainage Value
			From Previous Application	This Period Value					
90 00 02	PCO #002	7,434.00	0.00	0.00	0.00	0.00	0.00	7,434.00	0.00
<b>TOTAL:</b>		353,959.75	154,014.77	77,735.98	0.00	231,750.75	65.47	122,209.00	11,587.55

**Spreckels Memorial District**

---

**From:** Mike Locke <mikel@tomblesoninc.com>  
**Sent:** Friday, September 24, 2021 4:36 PM  
**To:** derek centralcoastengineers.com  
**Cc:** Spreckels Memorial District SMD  
**Subject:** FW: OUTDOOR BOTTLE FILLER WITH BUBBLER AND DOGGIE BOWL  
**Attachments:** ELKAY BF1.pdf; ELKAY BF2.pdf

**Importance:** High

Derek/ Paul,

Attached is a submittal for the drinking fountain someone was asking about. It has a bottle filler and a dog water spot  
It would be an additional \$1,200.00

Let me know as we need to confirm ordering. thanks

*Mike Locke*  
**TOMBLESON**  
— INCORPORATED —  
General Contractors  
BUILDING SINCE 1946  
CSLB # 426451  
P: 831.422.9696 • F: 831.422.0566

# ELKAY®

## SPECIFICATIONS

### Bi-Level Outdoor Tubular Bottle Filling Station Model LK4420BF

#### GENERAL

Pedestal steel bottle filler with textured power coat finish and E-Coat immersion for year-round beauty with minimum maintenance. The E-Coat immersion process coats the outside and inside of the unit for the ultimate in corrosion protection.

Configuration options:

- Single bottle filler in upper location with drinking fountain basin at lower position (Model LK4420BF1U)
- Single bottle filler in lower location with drinking fountain basin at upper position (Model LK4420BF1L)
- Dual bottle fillers (Model LK4420BF2)

#### NO LEAD DESIGN

This fountain is certified by WQA to lead-free compliance including **NSF/ANSI 61-ANNEX G, AB 1953**

This model complies with the lead-free definition in the Safe Drinking Water Act of 1986 and Lead Contamination Act of 1988.

#### CONSTRUCTION

**Bottle Filler:** Heavy-duty steel construction with rounded design. Laminar flow minimizes splash and allows easy maintenance. Quick fill rate at 1 gallon per minute.

**Pushbutton Actuation Mechanism:** Self-closing, vandal-resistant pushbutton does not require grasping or twisting.

**Inlet Strainer:** Easily cleaned in-line strainer screen traps particles of 140 microns or larger before they enter the waterway.

**Access Panel:** Manufactured of heavy-gauge steel with vandal-resistant screws. Provides access for easy hook-up of all plumbing connections.

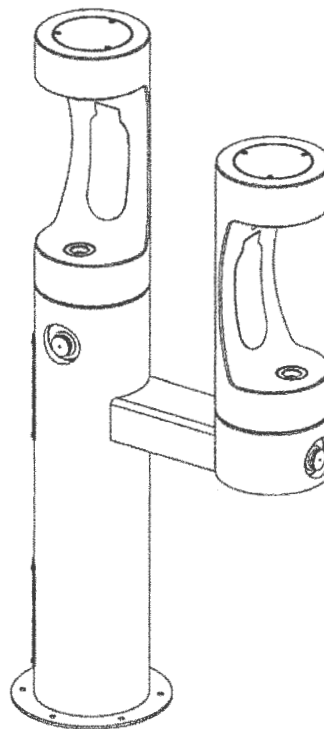

Model LK4420BF2 Shown



This model is ADA compliant when properly installed.

Designed to be easily accessible to both physically challenged and able-bodied individuals. Ideally suited for installation in public areas. Model meets state and federal requirements as defined by the Americans with Disabilities Act.

#### SUGGESTED SPECIFICATIONS

Unit shall be of tubular steel construction. Bottle Filler unit shall include laminar flow and front pushbutton activation. Stainless steel contoured basin with vandal-resistant one-piece bubbler, if applicable. Shall comply with ADA guidelines and be certified to lead-free compliance including NSF/ANSI 61, CA 1953 and the Safe Drinking Water Act.

**Shipping Weight:** 190-240 lbs.

#### AVAILABLE OPTIONS

Freeze-resistant option - add "FRK" suffix to model number. (See separate specification sheet.)

In keeping with our policy of continuing product improvement, Elkay reserves the right to change product specifications without notice.

This specification describes an Elkay product with design, quality and functional benefits to the user. When making a comparison of other producers' offerings, be certain these features are not overlooked.

**PRODUCT SPECIFICATIONS**

Elkay Outdoor ezH2O® Upper Bottle Filling Station, Bi-Level Pedestal with Pet Station Non-Filtered, Non-Refrigerated Freeze Resistant. Features shall include 316 Stainless, Heavy Duty Vandal Resistant, Laminar Flow, Pet Fountain, Sealed Freeze Resistant. Furnished with Vandal Resistant bubbler. Mechanical Front Bubbler Button activation. Product shall be Floor Mount/Freestanding, for Outdoor applications, serving 2 station(s). Unit shall be lead-free design which is certified to NSF/ANSI 61 & 372 (lead free) and meets Federal and State low-lead requirements.

<b>Special Features:</b>	316 Stainless, Heavy Duty Vandal Resistant, Laminar Flow, Pet Fountain, Sealed Freeze Resistant
<b>Finish:</b>	Beige (BGE), Black (BK), Blue (BLU), Brown (BRN), Evergreen (EVG), Gray (GRY), Orange (ORN), Powder Coat (12 Color Options), Purple (PUR), Red (RED), Terracotta (TER), White (WHT), Yellow (YLW)
<b>Power:</b>	No Electrical Required
<b>Bubbler Style:</b>	Vandal Resistant
<b>Activation by:</b>	Mechanical Front Bubbler Button
<b>Mounting Type:</b>	Floor Mount/Freestanding
<b>Chilling Capacity:</b>	Non-refrigerated
<b>Dimensions (L x W x H):</b>	26" x 31" x 64"
<b>Approx. Shipping Weight:</b>	224 lbs.
<b>Installation Location:</b>	Outdoor
<b>No. of Stations Served:</b>	2

\*\*When used in non-temperature controlled environments, unit(s) must be adequately winterized and/or protected from extreme heat to prevent damage where climates dictate.

**Special Note: Bottle Filler Stations 1 (Upper), Bubbler Stations 1 (Low), Choose from 12 color options**

- Mechanically-Activated bubbler continues to supply water in event of service disruptions.
- Laminar flow provides clean fill with minimal splash.
- Base material constructed from marine-grade 316 stainless steel provides the ultimate corrosion protection from even the most corrosive elements.
- Pet Fountain: Features slow drainage for easy drinking.
- Sealed Freeze Resistant Valve System: Fully sealed freeze resistant system that minimizes chance of ground water contamination, and prevents drain water from mixing with fresh water. Designed for ground installation below the frost line.

PART: \_\_\_\_\_ QTY: \_\_\_\_\_  
 PROJECT: \_\_\_\_\_  
 CONTACT: \_\_\_\_\_  
 DATE: \_\_\_\_\_  
 NOTES: \_\_\_\_\_  
 APPROVAL: \_\_\_\_\_



**Included with Product:** Outdoor Bottle Filler, Freeze Resistant Valve

**Ships in multiple boxes.**

AMERICAN PRIDE. A LIFETIME TRADITION. Like your family, the Elkay family has values and traditions that endure. For almost a century, Elkay has been a family-owned and operated company, providing thousands of jobs that support our families and communities.



**PRODUCT COMPLIANCE**

- ADA & ICC A117.1
- ASME A112.19.3/CSA B45.4
- Buy American Act
- GreenSpec®
- NSF/ANSI 61 & 372 (lead free)



 Complies with ADA & ICC A117.1 accessibility requirements when installed according to the requirements outlined in these standards. Installation may require additional components and/or construction features to be fully compliant. Consult the local Authority Having Jurisdiction if necessary.

[Installation Instructions \(PDF\)](#)

**Warranty pertains to drinking water applications only. Non-drinking water applications are not covered under warranty.**

[Warranty \(PDF\)](#)

*In keeping with our policy of continuing product improvement, Elkay reserves the right to change product specifications without notice. Please visit elkay.com for the most current version of Elkay product specification sheets. This specification describes an Elkay product with design, quality, and functional benefits to the user. When making a comparison of other producers' offerings, be certain these features are not overlooked.*



**PRODUCT SPECIFICATIONS**

Elkay Outdoor ezH2O® Lower Bottle Filling Station, Bi-Level Pedestal with Pet Station Non-Filtered, Non-Refrigerated Freeze Resistant. Features shall include 316 Stainless, Heavy Duty Vandal Resistant, Laminar Flow, Pet Fountain, Sealed Freeze Resistant. Furnished with Vandal Resistant bubbler. Mechanical Front Bubbler Button activation. Product shall be Floor Mount/Freestanding, for Outdoor applications, serving 2 station(s). Unit shall be lead-free design which is certified to NSF/ANSI 61 & 372 (lead free) and meets Federal and State low-lead requirements.

<b>Special Features:</b>	316 Stainless, Heavy Duty Vandal Resistant, Laminar Flow, Pet Fountain, Sealed Freeze Resistant
<b>Finish:</b>	Beige (BGE), Black (BK), Blue (BLU), Brown (BRN), Evergreen (EVG), Gray (GRY), Orange (ORN), Powder Coat (12 Color Options), Purple (PUR), Red (RED), Terracotta (TER), White (WHT), Yellow (YLW)
<b>Power:</b>	No Electrical Required
<b>Bubbler Style:</b>	Vandal Resistant
<b>Activation by:</b>	Mechanical Front Bubbler Button
<b>Mounting Type:</b>	Floor Mount/Freestanding
<b>Chilling Capacity:</b>	Non-refrigerated
<b>Dimensions (L x W x H):</b>	26" x 31" x 64"
<b>Approx. Shipping Weight:</b>	184 lbs.
<b>Installation Location:</b>	Outdoor
<b>No. of Stations Served:</b>	2

\*\*When used in non-temperature controlled environments, unit(s) must be adequately winterized and/or protected from extreme heat to prevent damage where climates dictate.

**Special Note: Bottle Filler Stations 1 (Low), Bubbler Stations 1 (Upper), Choose from 12 color options**

- Mechanically-Activated bubbler continues to supply water in event of service disruptions.
- Laminar flow provides clean fill with minimal splash.
- Base material constructed from marine-grade 316 stainless steel provides the ultimate corrosion protection from even the most corrosive elements.
- Pet Fountain: Features slow drainage for easy drinking.
- Sealed Freeze Resistant Valve System: Fully sealed freeze resistant system that minimizes chance of ground water contamination, and prevents drain water from mixing with fresh water. Designed for ground installation below the frost line.

PART: \_\_\_\_\_ QTY: \_\_\_\_\_  
 PROJECT: \_\_\_\_\_  
 CONTACT: \_\_\_\_\_  
 DATE: \_\_\_\_\_  
 NOTES: \_\_\_\_\_  
 APPROVAL: \_\_\_\_\_



**Included with Product:** Outdoor Bottle Filler, Freeze Resistant Valve

**Ships in multiple boxes.**

AMERICAN PRIDE. A LIFETIME TRADITION. Like your family, the Elkay family has values and traditions that endure. For almost a century, Elkay has been a family-owned and operated company, providing thousands of jobs that support our families and communities.



**PRODUCT COMPLIANCE**

- ADA & ICC A117.1
- ASME A112.19.3/CSA B45.4
- Buy American Act
- GreenSpec®
- NSF/ANSI 61 & 372 (lead free)



 Complies with ADA & ICC A117.1 accessibility requirements when installed according to the requirements outlined in these standards. Installation may require additional components and/or construction features to be fully compliant. Consult the local Authority Having Jurisdiction if necessary.

[Installation Instructions \(PDF\)](#)

**Warranty pertains to drinking water applications only. Non-drinking water applications are not covered under warranty.**

[Warranty \(PDF\)](#)

*In keeping with our policy of continuing product improvement, Elkay reserves the right to change product specifications without notice. Please visit elkay.com for the most current version of Elkay product specification sheets. This specification describes an Elkay product with design, quality, and functional benefits to the user. When making a comparison of other producers' offerings, be certain these features are not overlooked.*